

TEST REPORT

Mechanical & Hardgoods Laboratory

Report No. : HL60131C/2016

Page : 1 of 4

Date : AUG. 23, 2016

LifeProof

1017 RR 620 South, Suite 100, Austin, Texas 78734 USA

The following merchandise was submitted and identified by the applicant as:

Product Description: LifeProof Paint Coating

Style/Item No.: Ceramic Coating

Manufacturer/Vendor: LifeProof

Country of Origin: US

We have tested the submitted sample(s) as requested and the following results were obtained:

Test Requested:

1. Hardness by pencil
2. Alkali resistance
3. Salt solution resistance

Test Method and Result: --- See following sheet(s) ---

Date of Receipt: Jun. 07, 2016

Testing Period: Jun. 07, 2016 ~ Jun. 22, 2016

Signed for and on behalf of
SGS Taiwan Ltd.

Jackson Chen
Team Leader



This document is issued by the Company subject to its General Conditions of Service printed overleaf, available on request or accessible at <http://www.sgs.com/en/Terms-and-Conditions.aspx> and, for electronic format documents, subject to Terms and Conditions for Electronic Documents at <http://www.sgs.com/en/Terms-and-Conditions/Terms-e-Document.aspx>. Attention is drawn to the limitation of liability, indemnification and jurisdiction issues defined therein. Any holder of this document is advised that information contained hereon reflects the Company's findings at the time of its intervention only and within the limits of client's instruction, if any. The Company's sole responsibility is to its Client and this document does not exonerate parties to a transaction from exercising all their rights and obligations under the transaction documents. This document cannot be reproduced, except in full, without prior written approval of the Company. Any unauthorized alteration, forgery or falsification of the content or appearance of this document is unlawful and offenders may be prosecuted to the fullest extent of the law. Unless otherwise stated the results shown in this test report refer only to the sample(s) tested.

TEST REPORT

Mechanical & Hardgoods Laboratory

Report No. : HL60131C/2016

Page : 2 of 4

1. Hardness by pencil

Test Method:

Refer to JIS K5400(1990) Testing Methods for paints
(Gouge Hardness and Scratch Hardness)

Weight: 1000 g

The variety of pencil hardness :

6B - 5B - 4B - 3B - 2B - B - HB - F - H - 2H - 3H - 4H - 5H - 6H - 7H - 8H - 9H

Soft ←-----> Hard

Test Equipment :

Name	Brand	Model
Pencil	MITSU-BISHI	uni

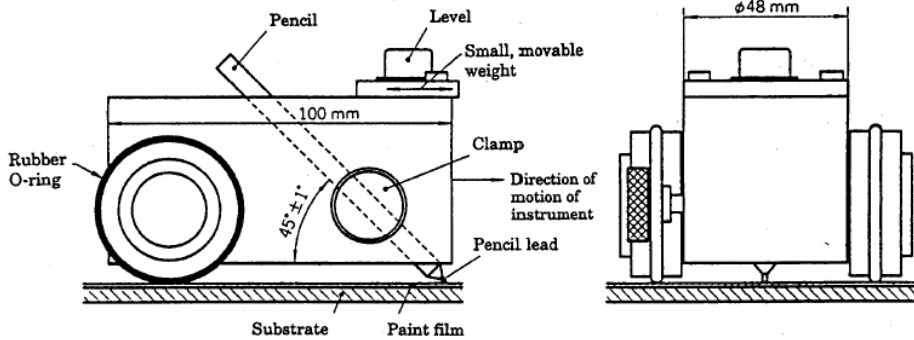

Lab Environmental Conditions:

Ambient temperature : $(23 \pm 2) ^\circ\text{C}$
Relative humidity : $(65 \pm 5) \% \text{RH}$

Test Results:

Sample	Result
LifeProof Paint Coating	9H, No scratch.

TEST REPORT

Mechanical & Hardgoods Laboratory

Report No. : HL60131C/2016

Page : 3 of 4

2. Alkali Resistance

Lab Environmental Conditions :

Ambient temperature : (23±2) °C
Relative humidity : (65±5) %RH

Test Method :

JIS K5400(1990) Testing Methods for Paints

Test Condition :

Test Procedure : Immersion
Test reagent : 5% Na₂CO₃
Test Temperature : 23 °C
Test time : 24 hours

Test Result :

Sample	Test Result(s)
LifeProof Paint Coating	There is no abnormality even immersed in alkali.

3. Salt Solution Resistance

Lab Environmental Conditions :

Ambient temperature : (23±2)°C
Relative humidity : (50±5)%RH

Test Method :

JIS K5400 (1990) Testing Methods for Paints

Test Condition :

Test Procedure : Immersion
Test reagent : 3% NaCl
Test Temperature : 23°C
Test time : 96 hours

Test Result :

Sample	Test Result(s)
LifeProof Paint Coating	There is no abnormality, even immersed in sodium chloride solution.

This document is issued by the Company subject to its General Conditions of Service printed overleaf, available on request or accessible at <http://www.sgs.com/en/Terms-and-Conditions.aspx> and, for electronic format documents, subject to Terms and Conditions for Electronic Documents at <http://www.sgs.com/en/Terms-and-Conditions/Terms-e-Document.aspx>. Attention is drawn to the limitation of liability, indemnification and jurisdiction issues defined therein. Any holder of this document is advised that information contained hereon reflects the Company's findings at the time of its intervention only and within the limits of client's instruction, if any. The Company's sole responsibility is to its Client and this document does not exonerate parties to a transaction from exercising all their rights and obligations under the transaction documents. This document cannot be reproduced, except in full, without prior written approval of the Company. Any unauthorized alteration, forgery or falsification of the content or appearance of this document is unlawful and offenders may be prosecuted to the fullest extent of the law. Unless otherwise stated the results shown in this test report refer only to the sample(s) tested.

TEST REPORT

Mechanical & Hardgoods Laboratory

Report No. : HL60131C/2016

Page : 4 of 4

– Pictures –

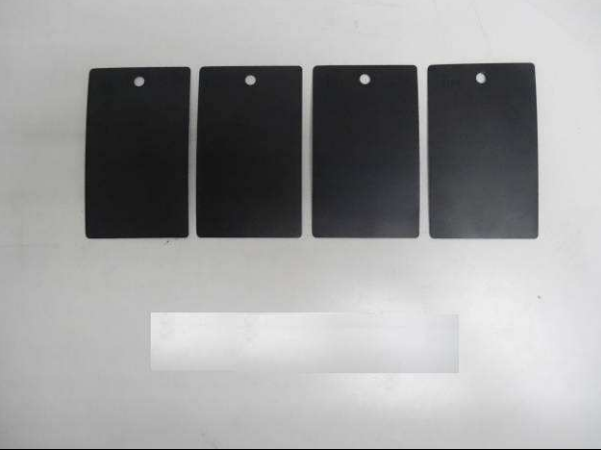
	
<p>Photo A : Appearance of the sample (Hardness by pencil)</p>	<p>Photo B : Appearance of the sample(s) (Alkali, Acid, Salt solution resistance)</p>

---End of Report---

This document is issued by the Company subject to its General Conditions of Service printed overleaf, available on request or accessible at <http://www.sgs.com/en/Terms-and-Conditions.aspx> and, for electronic format documents, subject to Terms and Conditions for Electronic Documents at <http://www.sgs.com/en/Terms-and-Conditions/Terms-e-Document.aspx>. Attention is drawn to the limitation of liability, indemnification and jurisdiction issues defined therein. Any holder of this document is advised that information contained hereon reflects the Company's findings at the time of its intervention only and within the limits of client's instruction, if any. The Company's sole responsibility is to its Client and this document does not exonerate parties to a transaction from exercising all their rights and obligations under the transaction documents. This document cannot be reproduced, except in full, without prior written approval of the Company. Any unauthorized alteration, forgery or falsification of the content or appearance of this document is unlawful and offenders may be prosecuted to the fullest extent of the law. Unless otherwise stated the results shown in this test report refer only to the sample(s) tested